

**MONITOR PRODUCTS, INC.**  
15400 Flight Path Dr  
Brooksville, FL 34604  
Tel: 800-334-4591  
Sales: ext 201  
Technical Assistance: ext 209  
Fax: 352-544-0870



REMOTE MOUNTED  
FRESHWATER COOLING  
KIT SPECIFICATIONS

MRM-5439

## MRM-5439 REMOTE MOUNTED FRESHWATER COOLING KIT

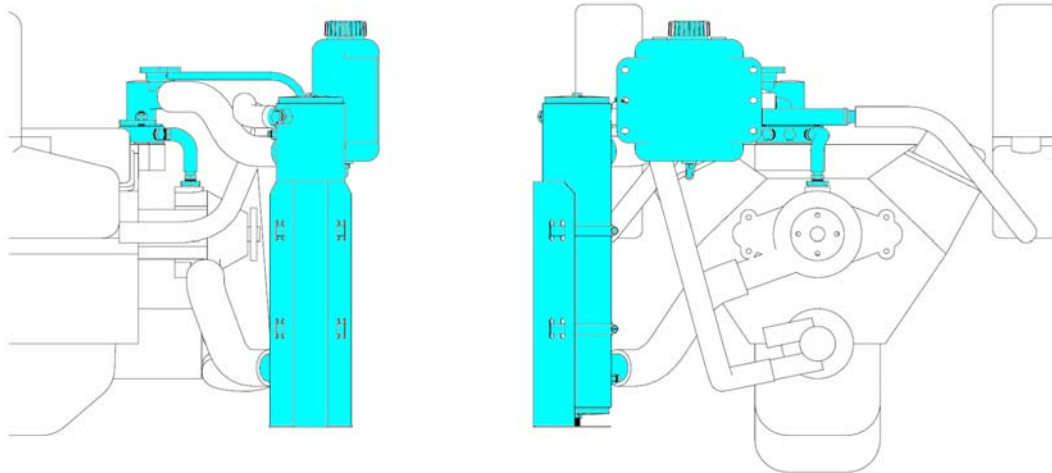

### **CONVERSION KIT FITS:**

This conversion kit fits 2000-present Volvo Penta 5.0l (305 CID) and 5.7l (350 CID) engines. It will also fit other small block Chevy-based engines were an on-engine installation is not practical. See space requirements to confirm that it will fit within the engine compartment.

### **COOLING SYSTEM TYPE:**

Off-engine remote mounted.

Block only. (The engine block protected by freshwater system; the exhaust manifold and exhaust elbow remain on raw water system.)

### **CONVERSION KIT:**

Kit includes heat exchanger, heavy-duty translucent plastic expansion tank plus other components necessary to complete conversion. ***Hoses and related hose clamps are not included.*** Some components from engine are reused. Heat Exchanger and Brackets are finished in black.

### **HEAT EXCHANGER:**

Heat exchanger is shell and tube type with special high capacity design. All copper alloy construction made to the highest industry standards. Includes dual demountable end covers for easy clean out.

**MONITOR PRODUCTS, INC.**  
15400 Flight Path Dr  
Brooksville, FL 34604  
Tel: 800-334-4591  
Sales: ext 201  
Technical Assistance: ext 209  
Fax: 352-544-0870



REMOTE MOUNTED  
FRESHWATER COOLING  
KIT SPECIFICATIONS

MRM-5439

### **SPACE REQUIREMENT:**

Before purchasing this system, make sure there is enough room in the engine compartment to accommodate the heat exchanger, expansion tank, and necessary components.

Heat exchanger is 4.13" diameter x 20" overall length (Approximately the size of two rolls of paper towels placed end to end). Heat exchanger should be mounted as close to the front of the engine as possible. The mounting bracket is included with the kit. **Note: The heat exchanger must be below the level of the filler neck on the thermostat housing.** The heat exchanger may be mounted on any horizontal or vertical surface. Monitor Products, Inc recommends a vertical mounting on the starboard side and slightly in front of the engine, it allows for easier hose routing and draining of the raw water side during winterization.

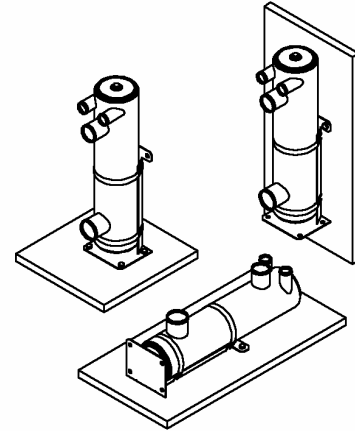

Expansion tank has to be mounted close to level with the filler neck. Required space is 4" x 9" x 9". The expansion tank must be mounted as close to the engine as possible.

It is recommended that you download a copy of the installation instructions from our website ([www.monitorpro.com](http://www.monitorpro.com)) and review them completely and do a mock installation using two rolls of paper towels placed end to end to represent the heat exchanger before purchasing to insure you have the space available to install the kit. This will also give you a chance to determine approximate hose lengths that will be needed for installation.

The mounting locations should not hinder the opening or closing of the hatch. Do not drill into fuel tanks, water tanks, or any other critical areas. Do not contact any belts or fuel lines.

### **COOLING SYSTEM CAPACITY:**

The heat exchanger will maintain coolant temperatures in the 160-170°F range using 160°F thermostat included in kit. The system has a cooling capacity safety margin higher than industry standards.

**MONITOR PRODUCTS, INC.**  
15400 Flight Path Dr  
Brooksville, FL 34604  
Tel: 800-334-4591  
Sales: ext 201  
Technical Assistance: ext 209  
Fax: 352-544-0870



REMOTE MOUNTED  
FRESHWATER COOLING  
KIT SPECIFICATIONS

MRM-5439

### **HEATER SYSTEM HOOKUP:**

Heaters such as galley water heaters and cabin heaters are easily connected to the system by utilizing the cooling system bypass connections.

### **INSTALLATION TIME:**

Average installation time is approximately 2-4 hours, assuming new engine and normal accessibility. Allow additional time for filling and testing. Installation skills are typical of most do-it-yourself boat owners. Complete illustrated installation instructions are included in kit.

### **WARRANTY**

Two year warranty. For complete details see Limited Warranty for Fresh Water Cooling Kits document enclosed with your kit and located on policies page of our website.

### **PRICE**

Trade and volume discounts available. Buy through your dealer or direct using Visa, MasterCard, Amex, UPS COD, or Money order.